



Information package for obtaining a building permit

To **apply** for a building permit, you must be a licensed contractor or the legal property owner. (Commercial permits may be obtained by an owner if the job does not exceed \$75,000 and property is an individual's name)

Electrical, Mechanical, Plumbing and the Roofing subcontractors must be listed at the time of application. Contractors/subcontractors must be registered with the Building Department. The permit application must be signed by the licensed contractor (instructions can be found on our website)

Powers of Attorney are NOT accepted for the permit application.

If you apply as an owner/builder, the building must be for your own use and occupancy. It may not be for sale or lease. If you sell or lease the building you have built as an owner builder within (1) one year after construction is completed, the law will presume that you have built it for sale or lease, which is a violation of Florida State Statute 489.103 (7).

It is the owner/builders responsibility to make sure the employees working for them have the required licenses from the state and/or county municipal licensing ordinances. Any person working on the building who is not licensed must work under the owner/builders direct supervision and must be employed by them. The owner/builder must provide worker's compensation as prescribed by Florida law as well as comply with the IRS requirements concerning F.I.C.A. and withholding taxes.

You may not hire an unlicensed contractor to perform the work.

Homeowners who hire unlicensed contractors face several potentially costly penalties. The Department of Business and Professional Regulation can issue an order to stop construction and can levy a five-thousand dollar (\$5,000.00) fine for aiding and abetting unlicensed contractors.

City of Palm Coast Important Phone Numbers

Area Code 386

Community Development Department (land development, planning, zoning questions, plats, general property questions)	986-3736
Building Division (general permitting, plan review and inspections – including fire)	986-3780
Inspection Request Line	986-4747
Zoning Division (setbacks, aesthetic requirements, landscaping)	986-3751
Construction Management and Engineering (commercial development, right of way, driveways, drainage, roadways)	986-3794
Code Enforcement (enforcement of ordinances, tree removal, wildfire mitigation, animal control, NOT building codes.)	986-3764
Business Tax Receipt	986-3766
St Johns River Water Management District <u>Compliance support@sjrmd.com</u> (SJRWMD encourages you to contact them prior to any clearing of your property)	329-4874

In addition to the requirements of a permit, there may be additional restrictions applicable to this property that may be found in the public records of this county, (including covenants and restrictions; there may be additional permits required from other governmental entities such as water management districts, state agencies or federal agencies.

Table of Contents for Requirements

		Patio / Slab / Pavers	Page 16
Single family/Duplex	Page 4	Shed/Accessory structure	Page 17
Green Build Single Family / Duplex	Page 5	Signs	Page 18
Additions/Renovations Including screen enclosures	Page 6	Irrigation	Page 19
Screen Enclosure/Aluminum	Page 7	Roofing	Page 20
Windows/Doors /Garage doors Electric/Mechanical/Plumbing Demolition	Page 7	Hurricane Shutters	Page 21
Pools, Spas and Solar	Pages 9 & 10	Driveway	Page 22
Fence/Walls	Page 11	Generator	Page 23
Docks/Boathouse/Boatlifts	Page 12	Gas Propane/piping	Page 24
Seawall	Page 13	Fire Permits	Page 25
Beautification Right Of Way	Page 14	Telecommunication towers	Page 26
Deck	Page 15	Commercial	Pages 27 & 28
		Lot clearing/ re-grading	Page 29 & 30

When a survey is required:

The foundation survey must provide indicate setbacks and finished floor elevation.

The final survey must provide setbacks, finished floor elevations, and topographic information.

Single family Residence / Duplex (see next page for green building)

- **Permit application** – signed by the licensed contractor if a contractor is hired.
- **Construction Drawings** - One set of signed and sealed construction drawings. (Include truss package, layout and fastening schedule)
- **Product Approval Spec Sheet** (detail/installation sheets to be in field at time of inspections)
- **Color/Material information** - Provide colors of all architectural features on elevation plans or on a separate attached paper, complete with manufacturer name and color description (including, but not limited to roof, exterior wall, trim, door, garage, brick, quoins, stone/rock, decorative shutters).
- **Energy Calculations** - One set of energy calculations.
- **Water and Sewer Receipt with stamped approved site plan attached.** (prior approval from utility)
- **Roofing worksheet**
- **Warranty Deed** - One copy of a recorded warranty deed
- **Construction Lien Law affidavit** (provided by contractor if job is valued over \$2500.00)
- **Owner/Builder disclosure** – this is required when an owner is obtaining a permit.
- **Early Power Affidavit**
- **Notice of Commencement** – a *certified copy* of the recorded notice of commencement is required for any job \$2500.00 or greater prior to the first inspection. (it is not required to submit for the permit)
- **Site Plans** - One site plan indicating the dimensions and setbacks from all structures to the property lines. Include patios, driveways, walkways, (materials and surface treatments).
- **Boundary Survey** - One copy of a sealed boundary survey indicating current flood zone by a licensed surveyor.
- Elevation Certificate – required if property lies within an “A” flood zone
- **Landscape Detail Plans** - One landscape detail plans showing the location of existing historic, specimen, understory, shade trees, and proposed trees. Include tree sizes, sod type, shrub size, type, and automatic irrigation system (if required). Plans must include foundation plantings for front, side street and rear structures facing saltwater canals, freshwater canals, lakes, golf courses and public right of ways.
- **Tree Survey** - One tree survey. (Survey to be no more than 24 months old and shall identify all protected trees by species name, and the size of the trunk measured at the diameter at breast height).
- One driveway detail plans equivalent in detail to the City of Palm Coast residential culvert detail available on the city website. (DWG NO 002-270605).
 - One sealed topographic surveys referencing 1988 NAVD datum/lot grading plan (see Stormwater req.) The survey should include the driveway width at the property line **and** at the edge of pavement **and** the distance from the proposed driveway flare to any road intersection within 75feet.
 - Grade elevation profile drawing is required when the proposed structure is on a saltwater canal lot.

A foundation survey is required prior to vertical construction

A final survey is required prior to final inspection

Boundary Survey, Landscape Detail Plans, and Tree Survey may be inclusive on one plan and must be labeled as such and is to be separate from the construction drawings.

GREEN BUILDING - Single family Residence / Duplex

- **Permit application** – signed by the licensed contractor if a contractor is hired.
- **Construction Drawings** - One set of signed and sealed construction drawings. Include product approval.
- **Green Home Certification Checklist**– Florida Green Building Coalition, Inc. Schedule A , Version 6.00
- **Color/Material information** - Provide colors of all architectural features on elevation plans or on a separate attached paper, complete with manufacturer name and color description (including, but not limited to roof, exterior wall, trim, door, garage, brick, quoins, stone/rock, decorative shutters).
- **Energy Calculations** - One sets of energy calculations.
- **Water and Sewer Receipt**
- **Roofing worksheet**
- **Warranty Deed** - One copy of a recorded warranty deed
- **Construction Lien Law affidavit** (provided by contractor if job is valued over \$2500.00)
- **Owner/Builder disclosure** – this is required when an owner is obtaining a permit.
- **Early Power Affidavit**
- **Notice of Commencement** – a *certified copy* of the recorded notice of commencement is required for any job \$2500.00 or greater prior to the first inspection. (it is not required to submit for the permit)
- **Site Plans** - One site plan indicating the dimensions and setbacks from all structures to the property lines. Include patios, driveways, walkways, (materials and surface treatments).
- **Boundary Survey** - One copy of a sealed boundary survey indicating current flood zone by a licensed surveyor.
- **Landscape Detail Plans** - One landscape detail plans showing the location of existing historic, specimen, understory, shade trees, and proposed trees. Include tree sizes, sod type, shrub size, type, and automatic irrigation system (if required). Plans must include foundation plantings for front, side street and rear structures facing saltwater canals, freshwater canals, lakes, golf courses and public right of ways.
- **Tree Survey** - One tree survey. (Survey to be no more than 24 months old and shall identify all protected trees by species name, and the size of the trunk measured a the diameter at breast height).
- One driveway detail plans equivalent in detail to the City of Palm Coast residential culvert detail available on the city website. (DWG NO 002-270605).
 - Three (3) sealed topographic surveys referencing 1988 NAVD datum/lot grading plan (see Stormwater req.) The survey should include the driveway width at the property line **and** at the edge of pavement **and** the distance from the proposed driveway flare to any road intersection within 75feet.
 - Grade elevation profile drawing is required when the proposed structure is on a saltwater canal lot.

A foundation survey is required prior to vertical construction

A final survey is required prior to final inspection

Additions/Renovations/ Screen Enclosures with solid roof
(screening existing porches/sunrooms/Florida rooms)

If the slab is existing, a letter from an engineer must be submitted verifying the existing slab is adequate to support the new structure

- **Permit application** – signed by the licensed contractor if a contractor is hired.
- **Construction Drawings** - One set of signed and sealed construction drawings to include truss package, layout and fastening schedule. Plans must include the elevation drawings of any/all sides being aesthetically changed by the addition. Existing floor plan and the proposed floor plan labeling all rooms including the intended ‘use’ of the proposed area, (plans MUST display means of egress) wall sections, bearing and shear walls, footings and re-enforcement, roof slope, overhang and method of ventilations mechanical diagram, (if no AC it to be provided, indicate method of heating) electrical diagram (including interconnected smoke detectors) door and window load calculations from the manufacturer.
- **Product Approval Spec Sheet**
- **Color/Material information** - Provide colors of all architectural features on elevation plans or on a separate attached paper, complete with manufacturer name and color description (including, but not limited to roof, exterior wall, trim, door, garage, brick, quoins, stone/rock, decorative shutters).
- **Energy Calculations** - One set of energy calculations *if area is to be heat/cooled.*
- **Roofing worksheet**
- **Warranty Deed** – must be recorded.
- **Construction Lien Law affidavit** (provided by contractor if job is valued over \$2500.00)
- **Owner/Builder disclosure** – this is required when an owner is obtaining a permit.
- **Notice of Commencement** – a *certified copy* of the recorded notice of commencement is required for any job \$2500.00 or greater prior to the first inspection. (it is not required to submit for the permit)
- **Site Plans** - One site plan indicating the size, dimensions and locations of the proposed addition and the setback dimensions from all existing structures to the property lines. Include patios, driveways, walkways, material and surface treatments.
- **Landscape Detail Plans** – One landscape detail plan indicating tree protection or removal requirements. If trees are not to be removed, you must write “No trees to be removed”. A tree removal permit may be required. Plant types, sizes, quantities, and locations (if applicable) sodded, mulched and undisturbed areas. The plans must include existing and proposed foundation plantings for front, side street and rear structures facing saltwater canals, freshwater canals, lakes, golf courses, and public right of ways.

If a foundation survey for the concrete involved in your project is not on file in our office, a foundation survey will be required prior to any vertical construction.

A final survey will be required prior to the final inspection.

Screen Enclosure/Aluminum

If the slab is existing, a letter from an engineer must be submitted verifying the existing slab is adequate to support the new structure.

- **Permit Application** - signed by the licensed contractor if contractor is to obtain permit.
- **Recorded Warranty Deed**
- **Construction Drawings** - One set of signed and sealed engineering drawings. All drawings must include the House/addition elevation drawings of any/all sides being aesthetically changed by the addition. Include intended use of proposed area.
- **Construction lien law affidavit** (provided by contractor if job is valued over \$2500.00)
- **Notice of Commencement** – a *certified copy* of the recorded notice of commencement is required for any job \$2500.00 or greater prior to the first inspection. (it is not required to submit for the permit)
- **Owner/Builder disclosure** – this is required when an owner is obtaining a permit.
- **Site Plan** - One site plan indicating the size, dimensions, and proposed location. Include setback dimensions from all existing structures to the property lines. Include patios, driveways, walkways, materials and surface treatments to be used.
- **Landscape Plan** – One landscape detail plan indicating tree protection or removal requirements. If trees are not to be removed, you must write “No trees to be removed”. A tree removal permit may be required. Plant types, sizes, quantities, and locations (if applicable) sodded, mulched and undisturbed areas. The plans must include existing and proposed foundation plantings for front, side street and rear structures facing saltwater canals, freshwater canals, lakes, golf courses, and public right of ways.

If a foundation survey for the concrete involved in your project is not on file in our office, a foundation survey will be required prior to any vertical construction.

Window/Door/Garage Door replacement

- **Permit Application** - signed by the licensed contractor if contractor is to obtain permit.
- **Product Approval Spec Sheet** (detail/installation sheets to be in field at time of inspections)
- **Recorded Warranty Deed**
- **Floor layout indicating locations of replacement(s)**
- **Construction lien law affidavit** (provided by contractor if job is valued over \$2500.00)
- **Notice of Commencement** – a *certified copy* of the recorded notice of commencement is required for any job \$2500.00 or greater prior to the first inspection. (it is not required to submit for the permit)
- **Owner/Builder disclosure** – this is required when an owner is obtaining a permit.

Electrical/Mechanical/Plumbing

- **Permit Application** - signed by the licensed contractor if contractor is to obtain permit.
- **Recorded Warranty Deed**
- **Two sets of Drawings** (AC Equipment change-outs must submit system verification (AHRI))
- **Site Plan** – one site plan if necessary
- **Construction lien law affidavit** (provided by contractor if job is valued over \$2500.00, Mechanical if over \$7500.00)
- **Notice of Commencement** – a *certified copy* of the recorded notice of commencement is required for any electric/plumbing job \$2500.00 or greater and any mechanical job \$7500.00 or greater, prior to the first inspection. (it is not required to submit for the permit)
- **Owner/Builder disclosure** – this is required when an owner is obtaining a permit.

Demolition

- **Permit Application** - signed by the licensed contractor if contractor is to obtain permit.
- **Recorded Warranty Deed**
- **One set of Construction Drawings** (not needed for disconnect / reconnects, AC change outs)
- **Site Plan** – One site plan indicating area to be demolished
- **Construction lien law affidavit** (provided by contractor if job is valued over \$2500.00)
- **Notice of Commencement** – a *certified copy* of the recorded notice of commencement is required for any electric/plumbing job \$2500.00 or greater and any mechanical job \$7500.00 or greater, prior to the first inspection. (it is not required to submit for the permit)
- **Owner/Builder disclosure** – this is required when an owner is obtaining a permit.

Swimming Pools

- **Permit application** - signed by the licensed contractor if contractor is to obtain permit.
- **Warranty Deed**
- **Construction Drawings** - One set of construction drawings. Signed and sealed drawings for pool construction may be filed in a master file. This will eliminate the need to submit signed and sealed drawings individually when submitting for a permit. (one time \$225.00 charge)
- **Total Dynamic Head Calculation Worksheet OR signed and sealed calculations.**
- **Aluminum Enclosure Drawings** - One set of enclosure plans if the pool is to be enclosed. Signed and sealed drawings for the aluminum enclosure may be filed in a master file. This will eliminate the need to submit signed and sealed drawings individually when submitting for a permit. (one time \$225.00 charge)
- **Construction Lien Law affidavit** (provided by contractor if job is valued over \$2500.00)
- **Notice of Commencement** – a *certified copy* of the recorded notice of commencement is required for any job \$2500.00 or greater prior to the first inspection. (it is not required to submit for the permit)
- **Owner/Builder disclosure** – this is required when an owner is obtaining a permit

- **Site Plan** – One site plan indicating the size, deck dimensions, the overall deck square footage (including pool area) and setback dimensions from pool deck/enclosure to the property lines. Site plans must include all equipment and door pads. Individual structures such as mechanical equipment and umps shall be screened by property owner with visual buffer planting, when visible from right of ways, parking areas, or adjacent properties. In lieu of a visual buffer planting, solid decorative fencing or walls may be installed to screen from public view. Plants used shall be native or shall be vegetarian that conserves water, is adaptable to local conditions, and is drought tolerant.

- **Landscape Plan** – One landscape detail plans indicating tree protection or removal requirements. If trees are not to be removed, you must write “No trees to be removed”. A tree removal permit may be required. Plant types, sizes, quantities, and locations (if applicable) sodded, mulched and undisturbed areas. The plans must include existing and proposed foundation plantings for front, side street and rear structures facing saltwater canals, freshwater canals, lakes, golf courses, and public right of ways. *No larger than 8 ½ x 14*

- **Topographic Survey** - One signed and sealed topographic survey – (less than 12 months old) using 1988 NAVD Datum, with a lot grading plan to comply with Stormwater Requirements effective November 1, 2007.

A final survey to include topographic (to include drainage) information must be submitted prior to the final inspection.

Above Ground Pools

— **Permit application**

— **Site Plan** - One site plans indicating the setback dimensions from pool deck/enclosure to the property lines.
No larger than 8 ½ x 14

- Water meter pit and pep tank panel located on site plan
- If a fence is to be included with the permit, the location, color, material, and height of fence must be included on the site plan. Screening for fences along rear or side lot lines abutting a right of way, golf course, or saltwater canal shall be facilitated by setting the fence back a minimum of three (3) feet from the property line and installing shrubs or vines on the outside of the fence for softening and enhancement. This requirement also applies to any fence facing the front or side corner of the property. This requirement applies to all types of fencing.

— **Manufacturer's Drawings** - One copy of the manufactures' drawings for the pool assembly.

— **Construction Lien Law affidavit** (provided by contractor if job is valued over \$2500.00)

— **Warranty Deed**

— **Notice of Commencement** – a *certified copy* of the recorded notice of commencement is required for any job \$2500.00 or greater prior to the first inspection. (it is not required to submit for the permit)

— **Owner/Builder disclosure** – this is required when an owner is obtaining a permit.

Solar

— **Permit Application**

— **Manufacturer Drawings** – Two set of plans / Manufactures Specifications

— **Owner/Builder disclosure** – this is required when an owner is obtaining a permit

— **Warranty Deed**

— **Notice of Commencement** – a *certified copy* of the recorded notice of commencement is required for any job \$2500.00 or greater prior to the first inspection. (it is not required to submit for the permit)

— **Construction Lien Law affidavit** (provided by contractor if job is valued over \$2500.00)

If solar panels are located on the ground, the panels must be completely screened by landscaping or an opaque fence.

Fence/Wall

— Permit Application

— Two copies Site Plan

- Indicate water meter pit and pep tank panel. The fence must be 3' from the pep panel.
- Indicate the location of the pep tank.

- One site plan which indicate the property lines, roadways, waterways, easements, all existing structures, and proposed fence location, color, height and material, location, size and swing of any/all gates, with the setback measurements to the property line. Indicate tree protection or removal requirements. If trees are not being removed, you must write "no trees to be removed". If trees are to be removed, a tree removal permit may be required. Screening for fences along rear or side lot lines abutting a right of way, golf course, or saltwater canal shall be facilitated by setting the fence back a minimum of three (3) feet from the property line and installing shrubs or vines on the outside of the fence for softening and enhancement. This requirement also applies to any fence facing the front or side corner of the property. This requirement applies to all types of fencing.

— **Construction Drawings** - Walls will require two sets of plans signed and sealed by a licensed Florida Architect or Engineer. Plans must include the linear square footage, dimensions, column spacing and finished cap.

— **Construction Lien Law affidavit** (provided by contractor if job is valued over \$2500.00)

— **Warranty Deed** - One copy of a recorded warranty deed

— **Tenant Affidavit** - this is required if property owner is NOT the applicant.

— **Notice of Commencement** – a *certified copy* of the recorded notice of commencement is required for any job \$2500.00 or greater prior to the first inspection. (it is not required to submit for the permit)

— **Owner/Builder disclosure** – this is required when an owner is obtaining a permit.

Docks and Boathouses/Boat Lifts

In accordance with the Palm Coast Restrictive Covenant and Easements you may not extend into the waterbody more than 12' unless such waterbody is 100' or more in width. If so, same may extend 16', in both instances as measured at right angles to and from the property line abutting the waterbody.

- **Permit Application** - signed by the licensed contractor if contractor is to obtain permit.

- **Construction Drawings** - One set of signed and sealed construction drawings (if lift station for boat, a copy of the electrical drawing and power source is required. Drawings must be clean and concise, drafted to scale, showing all types of materials, sizes, dimensions and locations. Include any other details necessary to convey design/construction intent. Brochures or photographs which include all dimension and material information are acceptable to show design. ALL DOCKS MUST HAVE A HIP STYLE ROOF.

- **Site Plan** - One set of the site plan which must include a drafted to scale professional drawing to show the lot, property lines, proposed structure location and width of the canal. All dimensions must be included on the site.

- **Warranty Deed**

- **Construction Lien Law affidavit** (provided by contractor if job is valued over \$2500.00)

- **Notice of Commencement** – a *certified copy* of the recorded notice of commencement is required for any job \$2500.00 or greater prior to the first inspection. (it is not required to submit for the permit)

- **Owner/Builder disclosure** – this is required when an owner is obtaining a permit.

The Intracoastal Waterway must require all appropriate state and federal permits prior to permit submittal (Army Corps. Engineers, DEP, SJRWMD, SFRWMD). In addition, a database search from Florida Natural Areas Inventory, US Fish and Wildlife Services to list plant and animal species that have potential to occur on property.

Seawall

- **Permit Application** - signed by the licensed contractor if contractor is to obtain permit.
- **Warranty Deed**
- **Construction Drawings** - One sets of signed and sealed scaled drawings to include detailed construction of the proposed bulkhead or coquina riprap.
- **Site Plan** – One set of the site plan which must indicate a drafted to scale professional drawing to show the lot, property lines, proposed bulkhead/riprap location and width of canal. All dimensions must be included on this site plan.
- **Right of Way Access Application**
- **Construction Lien Law affidavit** (provided by contractor if job is valued over \$2500.00)
- **Notice of Commencement** – a *certified copy* of the recorded notice of commencement is required for any job \$2500.00 or greater prior to the first inspection. (it is not required to submit for the permit)
- **Owner/Builder disclosure** – this is required when an owner is obtaining a permit.

Beautification Right of Way

(To clear property belonging to the city that abuts your property)

- **Permit Application** - signed by the licensed contractor if contractor is to obtain permit.
- **Right of Way Access Application**
- **Site plan** indicating measurements from both sides of the rear property line to the waters edge, measurements from both side property lines to the proposed ROW. The 20' ROW must be shown and the amount of type of trees that are to be removed.
- **Owner/Builder disclosure** – this is required when an owner is obtaining a permit.
- **Notice of Commencement** – a *certified copy* of the recorded notice of commencement is required for any job \$2500.00 or greater prior to the first inspection. (it is not required to submit for the permit)

Requirements:

- Must be set back 10' from side property lines
 - ROW may be anywhere between both side property line setbacks
 - All work in ROW must be done by hand. (no heavy equipment permitted)
 - Any disturbed areas must be stabilized immediately
 - All areas outside the BROW are to remain natural
- Sample

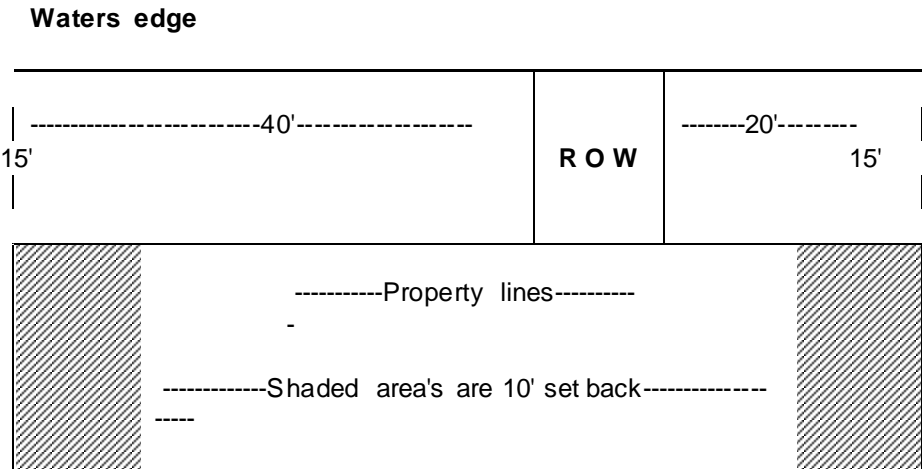

Deck

(Wooden with no roof)

- **Permit Application**
- **Construction Drawings** –One set of signed and sealed construction drawings (by licensed Florida Architect or Engineer)
- **Recorded Warranty Deed**
- **Site Plan** – One signed and sealed survey which indicates the property lines, easements, size, dimension and locations of proposed and all existing structures with the setback dimensions to the property lines. *No*
- **Landscape Plan** – One landscape detail plan indicating tree protection or removal requirements. If trees are not to be removed, you must write “No trees to be removed”. A tree removal permit may be required. Plant types, sizes, quantities, and locations (if applicable) sodded, mulched and undisturbed areas. The plans must include existing and proposed foundation plantings for front, side street and rear structures facing saltwater canals, freshwater canals, lakes, golf courses, and public right of ways.
- **Construction Lien Law affidavit** (provided by contractor if job is valued over \$2500.00)
- **Notice of Commencement** – a *certified copy* of the recorded notice of commencement is required for any job \$2500.00 or greater prior to the first inspection. (it is not required to submit for the permit)
- **Owner/Builder disclosure** – this is required when an owner is obtaining a permit.

Slab/Patio

(Concrete only– no roof)

- **Permit application**
 - **Recorded Warranty Deed**
 - **Construction Drawings** – One set of engineered drawings. Required if slab is to structural (with footers).
 - **Site Plans** - One site plan which indicates the property lines, all existing structures and proposed structures location with the setback dimensions to the property lines. *Site plans must include the location of the water meter pit.*
 - **Landscape Plan** –One landscape detail plan indicating tree protection or removal requirements. If trees are not to be removed, you must write “No trees to be removed”. A tree removal permit may be required. Plant types, sizes, quantities, and locations (if applicable)
- sodded, mulched and undisturbed areas. The plans must include existing and proposed foundation plantings for front, side street and rear structures facing saltwater canals, freshwater canals, lakes, golf courses, and public right of ways.
- **Construction lien law affidavit** (provided by contractor if job is valued over \$2500.00)
 - **Notice of Commencement** – a *certified copy* of the recorded notice of commencement is required for any job \$2500.00 or greater prior to the first inspection. (it is not required to submit for the permit)
 - **Owner/Builder disclosure** – this is required when an owner is obtaining a permit.

A foundation survey will be required if a structural patio is poured.

Paver Installation

- Permit application
- Recorded warranty deed
- **Site Plans** - One site plan which indicate the property lines, all existing structures and proposed structures location with the setback dimensions to the property lines. **Site plans must include the location of the water meter pit. No larger than 8 ½ x 14**
- **Landscape Plan** – One landscape detail plan indicating tree protection or removal requirements. If trees are not to be removed, you must write “No trees to be removed”. A tree removal permit may be required. Plant types, sizes, quantities, and locations (if applicable) sodded, mulched and undisturbed areas. The plans must include existing and proposed foundation plantings for front, side street and rear structures facing saltwater canals, freshwater canals, lakes, golf courses, and public right of ways.
- **Notice of Commencement** – a *certified copy* of the recorded notice of commencement is required for any job \$2500.00 or greater prior to the first inspection. (it is not required to submit for the permit)
- **Owner/Builder disclosure** – this is required when an owner is obtaining a permit.

Shed/Accessory Structure

- **Permit Application**
- **Recorded Warranty Deed**
- **Manufacturers Drawings** -Two copies of the manufactures drawings for the shed assembly, OR two copies of signed and sealed drawings for an accessory structure (detached garage, gazebo, etc.) Plans must include height – a shed is to be no more than 12’ tall. Plans must include diagram for anchoring system (must meet 120 mph wind load requirements).
- **Roofing Material Worksheet** -if shed is to be built on-site (not pre-manufactured)
- **Site Plan** - Two site plan which indicate the property lines, roadways, waterways, easements, all existing structures, and proposed structure. Indicate tree protection or removal requirements. If trees are not being removed, you must write “no trees to be removed”. Individual Structures such as sheds shall be screened by the property owner with a visual buffer planting, solid decorative fencing or walls may be installed to screen from public view. Plants used shall be native or shall be vegetation that conserves water, is adaptable to local conditions, and is drought tolerant.
 - Include size, dimension and location
 - Include all setbacks to property lines
 - Include colors and materials of the shed exterior and roof
- **Tenant Affidavit** - if property owner is NOT the applicant
- **Construction Lien Law affidavit** (provided by contractor if job is valued over \$2500.00)
- **Notice of Commencement** – a *certified copy* of the recorded notice of commencement is required for any job \$2500.00 or greater prior to the first inspection. (it is not required to submit for the permit)
- **Owner/Builder disclosure** – this is required when an owner is obtaining a permit.

Signs

Multiple wall signs may be permitted together. Monument signs require separate applications for each.

— **Permit application**

- **Construction Drawings** - One set of engineered drawings - must include electrical drawing if sign to be lighted.
- **Colored Renditions** - One set of colored renditions that show the elevation and linear frontage of the building as well as all dimensions and sign areas (in square footages)
- **Site Plan** – One site plan is required for free-standing / monument signs to include the lot frontage, the location of the signs from the property lines, building and other existing signs.
- **Tree Survey** – One tree survey is required for free-standing / monument signs. Survey must be less than 24 months and identify all protected trees by species name and the size of the trunk measured at the diameter at breast height. Where monument signs are proposed to be located on any development, all protected trees that are located within fifty (50) feet of the proposed sign shall be shown on the tree survey.
- **Tenant Affidavit** - if property owner is NOT the applicant
- **Notice of Commencement** – a *certified copy* of the recorded notice of commencement is required for any job \$2500.00 or greater prior to the first inspection. (it is not required to submit for the permit)

Temporary signs and Construction Signs

All documents submitted **MUST** be original – no photo/fax copies will be accepted.

— **Permit application**

- **Site Plans** - One site plan which indicate property lines, all existing structures and proposed location of sign(s) with the setback dimensions to the property lines.
- **Construction Drawings** - One set of engineering drawings
- **Authorization letter** - from property owners (if applicant is not legal property owner).

Irrigation (Residential)

Required only if located within right of way

- **Permit Application**
- **Recorded Warranty Deed**
- **Right of Way application**
- **Site Plans** - One site plan depicting location of sprinkler heads - (POP UP types only allowed in right of way).

Irrigation (commercial)

Not required on new construction sites

- **Permit application**
- **Recorded Warranty Deed**
- **Right of Way application** - if work is to commence in right of way
- **Construction Lien Law affidavit** (provided by contractor if job is valued over \$2500.00)
- **Tenant Affidavit** - if property owner is NOT the applicant
- **Notice of Commencement** – a *certified copy* of the recorded notice of commencement is required for any job \$2500.00 or greater prior to the first inspection. (it is not required to submit for the permit)
- **Owner/Builder disclosure** – this is required when an owner is obtaining a permit.

Roofing

— **Permit Application**

— **Tile Roofs** - must submit copy of plans with a letter from an engineer OR the plans indicating the trusses can support the weight of the tile.

— **Recorded Warranty Deed**

— **Roofing Worksheet** - to include product approval numbers. (product approval detail /installation sheets to be at jobsite for inspection)

— **Construction Lien Law affidavit** (provided by contractor if job is valued over \$2500.00)

— **Notice of Commencement** – a *certified copy* of the recorded notice of commencement is required for any job \$2500.00 or greater prior to the first inspection. (it is not required to submit for the permit)

— **Owner/Builder disclosure** – this is required when an owner is obtaining a permit.

— **Roofing Affidavit** (offered to contractor only) - option of using affidavit or a roof sheathing inspection.

A Roof Sheathing inspection is required by owner/builders.

Hurricane Shutters

- **Permit Application**
- **Recorded Warranty Deed**
- **Product Approval Spec Sheet** (detail/installation sheets to be in field at time of inspections)
- **Elevation plan** - One plan indicating location, color, type and style
- **Construction Lien Law affidavit** (provided by contractor if job is valued over \$2500.00)
- **Notice of Commencement** – a *certified copy* of the recorded notice of commencement is required for any job \$2500.00 or greater prior to the first inspection. (it is not required to submit for the permit)
- **Owner/Builder disclosure** – this is required when an owner is obtaining a permit.

Driveway

- **Permit Application**
- **Recorded warranty deed**
- **Construction Lien Law affidavit** (provided by contractor if job is valued over 2500.00)

- **Site Plans** - one site plan which indicate the property lines, all existing structures and proposed driveway location with the setback dimensions to the property lines.
 - The water meter pit location must be indicated, pouring a driveway over a water meter pit is prohibited.
 - Depict the driveway width at the property line and the edge of the road, and the distance from the proposed driveway to the edge of pavement of any road intersection within 75 feet.

- **Notice of Commencement** – a *certified copy* of the recorded notice of commencement is required for any job \$2500.00 or greater prior to the first inspection. (it is not required to submit for the permit)

Driveways must be in accordance with the City of Palm Coast residential culvert detail

See Stormwater/Engineering Documents for detail

Generator

If the gas company obtains the permit, they must list the electrical contractor as a sub. If the electrical company obtains the permit, they must list the gas contractor as a sub – **NO EXCEPTIONS**

- **Permit application**
- **Recorded Warranty Deed**
- **Construction Lien Law affidavit** (provided by contractor if job is valued over 2500.00)
- **Notice of Commencement** – a *certified copy* of the recorded notice of commencement is required for any job \$2500.00 or greater prior to the first inspection. (it is not required to submit for the permit)
- **Owner/Builder disclosure** – this is required when an owner is obtaining a permit.
- **Construction Drawings** - One of plans to include: manufactures specifications including the generator transfer switch, the BTU rating of each appliance served, the type of pipe to be used, the size of pipe to each appliance and the length of the pipe run to each appliance.
- **Site Plan** - One site plan depicting flood zone, size, location, setbacks, dimensions of generator and the concrete pad. Setbacks must include from house to generator, and generator to property line. Survey must show proposed gas tank, indicate if it is to be located above or below ground. Show dimensions, size, location and setbacks for the tank. Individual structures such as mechanical equipment and pumps shall be screened by property owner with visual buffer planting, when visible from rights-of-way, parking areas, or adjacent properties. In lieu of a visual buffer planting, solid decorative fencing or walls may be installed to screen from public view. Plants used shall be native or shall be vegetation that conserves water, is adaptable to local conditions, and is drought tolerant

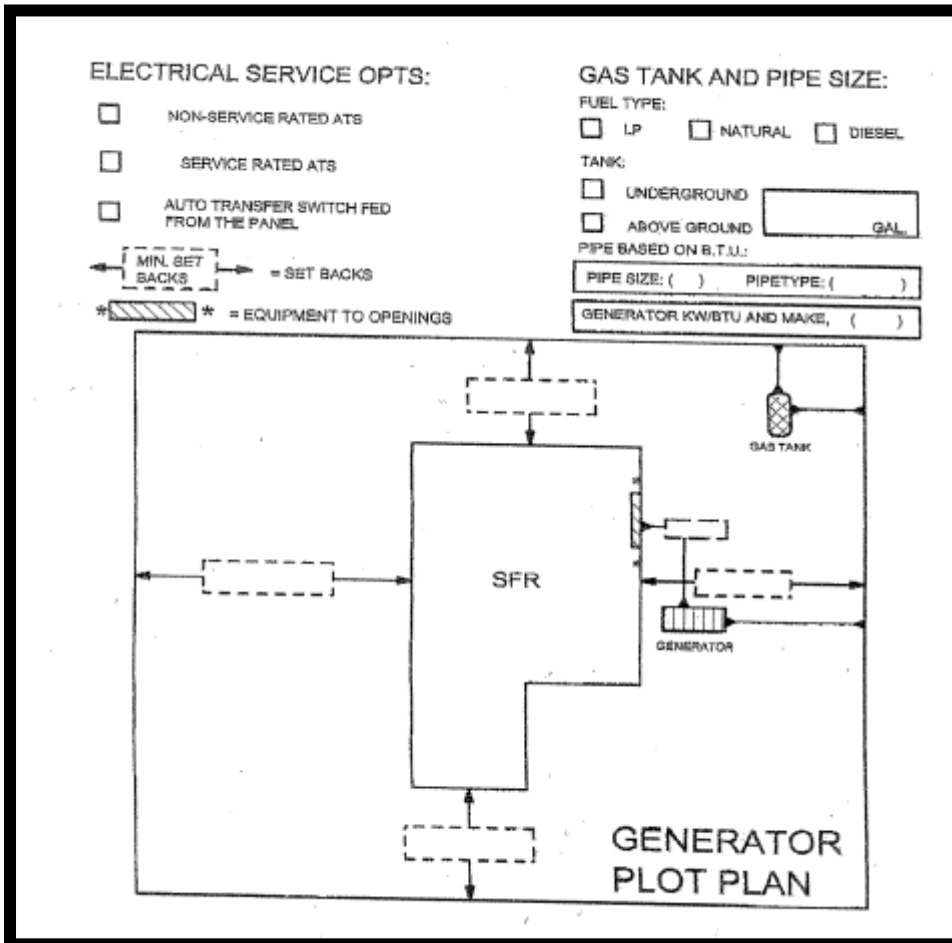

Special Hazard Flood Zones A and AE must be 1 foot above base flood elevation if an AW Zone or 2 feet above the highest adjacent grade is in an A Zone. If the tank is in a special hazard Flood Zone, provide technical data for the tank anchoring system to indicate it will not become buoyant during a flood or place that tank above the flood base elevation.

Gas/Propane Tank and piping

- **Permit Application**
- **Recorded Warranty Deed**
- **Construction Drawings** - One set of plans that include: BTU rating of each appliance served, the type of pipe to be used, the size of pipe to each appliance and the length of the pipe run to each appliance.
- **Site Plan** - One site plan depicting flood zone, size, location, setbacks, dimensions of generator and the concrete pad. Setbacks must include from house to generator, and generator to property line. Survey must show proposed gas tank, indicate if it is to be located above or below ground. Show dimensions, size, location and setbacks for the tank. Individual structures such as mechanical equipment and pumps shall be screened by property owner with visual buffer planting, when visible from rights-of-way, parking areas, or adjacent properties. In lieu of a visual buffer planting, solid decorative fencing or walls may be installed to screen from public view. Plants used shall be native or shall be vegetation that conserves water, is adaptable to local conditions, and is drought tolerant
- **Notice of Commencement** – a *certified copy* of the recorded notice of commencement is required for any job \$2500.00 or greater prior to the first inspection. (it is not required to submit for the permit)
- **Owner/Builder disclosure** – this is required when an owner is obtaining a permit.

Special Hazard Flood Zones A and AE must be 1 foot above base flood elevation if an AW Zone or 2 feet above the highest adjacent grade is in an A Zone. If the tank is in a special hazard Flood Zone, provide technical data for the tank anchoring system to indicate it will not become buoyant during a flood or place that tank above the flood base elevation.

Fire Permits

(Hood installation, Ansul,
Alarms, Suppression, Sprinkler, Fuel Tank Installation)

- **Permit application**
- **Plans** –One set of plans
- **Site Plans** - One site plan (necessary for fuel tank installation)
- **Notice of Commencement** – a *certified copy* of the recorded notice of commencement is required for any job \$2500.00 or greater prior to the first inspection. (it is not required to submit for the permit)
- **Notice of Commencement Recording Affidavit** – in lieu of a notice of commencement – if you are not in direct contract with the property owner and have contracted your services with the general contractor, you may fall under the general's NOC and submit the affidavit.
- **Tenant Affidavit** (if not property owner) - this is to allow the tenant to make improvements to real property.

Telecommunication
Tower/Co-Location/Unmanned Buildings, Concrete, etc.

For tower information contact the Information Technology and Communication Department
386-986-4732

For new towers and changes to existing site, a development order must be issued through the Planning Division prior to application for a building permit.

— Permit Application

— \$3500.00 is due at time of application submittal for plan review (by consultants)

— Site plan indicating all existing and proposed development.

— Structural plans

— Co-locations require a structural analysis from licensed engineer stating the structure is sufficient to support the proposed antenna.

— Development Order (if applicable)

Site Development Permit

A site development permit will be issued with each commercial permit.
Commercial permits will not be issued until a site development is issued.

— **Permit Application**

— **Development Order**

Landscaping and Irrigation are included on the site development permit.

Commercial Additions/Alterations

All documents submitted **MUST** be original – no photo/fax copies will be accepted.

General, electrical, mechanical, plumbing and roofing contractors are required to submit for a permit.

Contractors must be registered in the Building Department database.

— **Permit Application**

— **Construction Drawings** - One set of signed and sealed construction drawings. (by licensed Florida Architect or Engineer) Floor plan to show all areas and specify USE and square footage. Calculate seating area of indoor and outdoor if applicable.

— **Parking Lot Layout** - 1 sets of existing parking layout to include handicap parking

— **Roofing worksheet** (if roof to be altered – added)

— **Energy Calculations** (if applicable)

— **Notice of Commencement** – a *certified copy* of the recorded notice of commencement is required for any job \$2500.00 or greater prior to the first inspection. (it is not required to submit for the permit)

— **Tenant Affidavit** (if not property owner) - this is to allow the tenant to make improvements to real property.

— **Owner/Builder disclosure** – this is required when an owner is obtaining a permit. (only permitted up to \$75,000 work and it must be a private individual, not a corporation, etc.)

Site Development Permit

A site development permit will be issued with each commercial permit.
Commercial permits will not be issued until a site development is issued.

— **Permit Application**

— **Development Order**

Commercial (new construction)

All documents submitted **MUST** be original – no photo/fax copies will be accepted.
General, electrical, mechanical, plumbing and roofing contractors are required to submit for a permit.
Contractors must be registered in the Building Department database.

— **Permit application**

— **Construction Drawings** - One sets of signed and sealed complete engineered construction drawings designed to meet requirements of the Florida Building Code.

— **Energy Calculations** – One copy

— **Roofing worksheet**

— **Well Permit or Water Receipt**

— **Recorded Warranty Deed**

— **Boundary Survey**

— **Notice of Commencement** – a *certified copy* of the recorded notice of commencement is required for any job \$2500.00 or greater prior to the first inspection. (it is not required to submit for the permit)

Temporary Sales/Office/Construction trailers require a separate permit

Sales/Office Trailer

- Completed application
- One set of plans to include concrete slab or stem wall and required anchoring.
- Site plan to include :
 - Location of trailer
 - Location of electric meter
 - Parking
 - Fencing
 - Signage
 - landscaping
 - water/wastewater facilities

Construction Trailer

- Completed application
- Site plan to include:
 - Location of trailer
 - Location of electric meter
 - water/wastewater facilities

Lot Clearing

(Vacant)

- **Permit Application**
- **Right Of Way Application**
- **Topographic Survey** with elevation data in 1988 NAVD following Stormwater guidelines.
- **Hardwood trees over 6” in caliper should be noted on the survey.**
- **Grading plan** with grade proposals and trees that are to be removed. (Note: the site needs to maintain a minimum of 1 tree / 2500 square feet of total lot area after work is completed. Existing trees to remain must be barricaded and protected).
- **Testing Agency Documentation** - For lots that are partially clearing to remove unsuitable fill, written proof from a testing agency of unsuitable fill is required.
- **Notice of Commencement** – a *certified copy* of the recorded notice of commencement is required for any job \$2500.00 or greater prior to the first inspection. (it is not required to submit for the permit)
- **Owner/Builder disclosure** – this is required when an owner is obtaining a permit.

Note: a final topographic survey will be required for final inspections to ensure that the swale meets the required grade and the lot complies with the grading plan. For lots with unsuitable fill, only restoration of the access point will be required.

Lot Re-Grading

(not vacant)

- **Permit Application**
- **Right Of Way Application**
- **Site plan** identifying the scope of work, a grading plan, and the location of any hardwood trees over 6” in caliper. Existing trees must be barricaded and protected.
- **Notice of Commencement** – a *certified copy* of the recorded notice of commencement is required for any job \$2500.00 or greater prior to the first inspection. (it is not required to submit for the permit)
- **Owner/Builder disclosure** – this is required when an owner is obtaining a permit.

Note: for extensive work a topographic survey may be required for the permit application and a final survey for the final inspection.

- Lot Clearing and Grading permits will require reviews by the Zoning, Stormwater and Urban Forestry Departments.